

CIVE 530 - OPEN-CHANNEL HYDRAULICS

LECTURE 17: HEC-RAS, Chapter 6, Modeling culverts

MODELING CULVERTS

- **HEC-RAS computes energy losses, caused by structures such as culverts, in three parts.**
- **The first part consists of losses that occur in the reach immediately downstream from the structure, where an expansion of flow takes place.**
- **The second part consists of losses that occur as flow travels into, through, and out of the culvert.**
- **The last part consists of losses that occur in the reach immediately upstream from the structure, where the flow is contracting towards the opening of the culvert.**
- **HEC-RAS has the ability to model single culverts; multiple identical culverts; and multiple non-identical culverts.**
- **This chapter discusses how culverts are modeled within HEC-RAS.**
- **Discussions include: general modeling guidelines; how the hydraulic computations through the culvert are performed; and what data are required and how to select the various coefficients.**

GENERAL MODELING GUIDELINES

- **The culvert routines in HEC-RAS are similar to the bridge routines, except that the Federal Highway Administration's (FHWA, 1985) standard equations for culvert hydraulics are used to compute inlet control losses at the structure.**
- **Figure 6.1 illustrates a typical box culvert road crossing.**

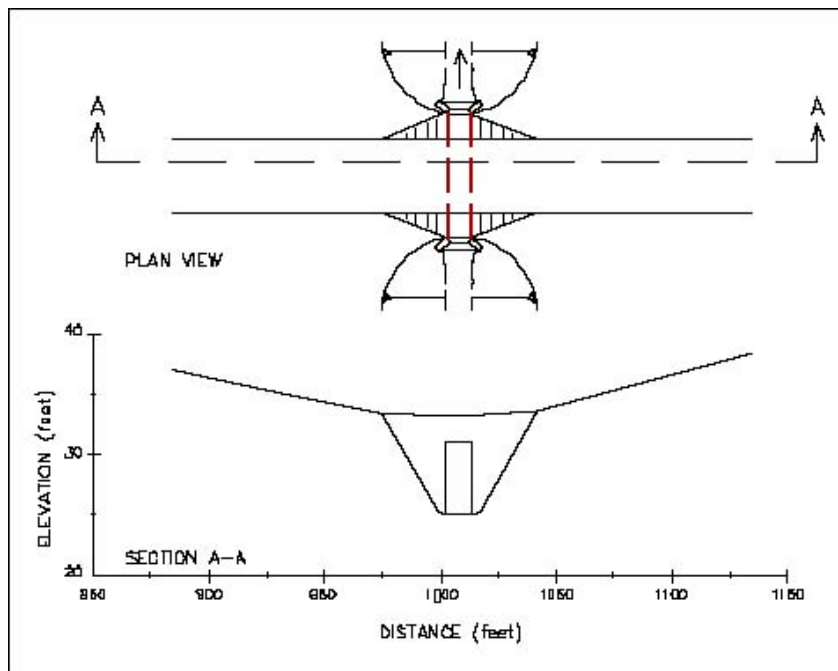

Figure 6.1 Typical culvert road crossing.

- As shown, the culvert is similar to a bridge in many ways.
- The walls and roof of the culvert correspond to the abutments and low chord of the bridge, respectively.
- Because of the similarities between culverts and other types of bridges, culverts are modeled in a similar manner to bridges.
- The layout of cross sections, the use of the ineffective areas, the selection of loss coefficients, and most other aspects of bridge analysis apply to culverts as well.

Types of Culverts

- HEC-RAS has the ability to model nine of the most commonly used culvert shapes.
- These shapes include: circular; box (rectangular); arch; pipe arch; low profile arch; high profile arch; elliptical (horizontal and vertical); semi-circular, and Con/Span culverts (Figure 6.2).

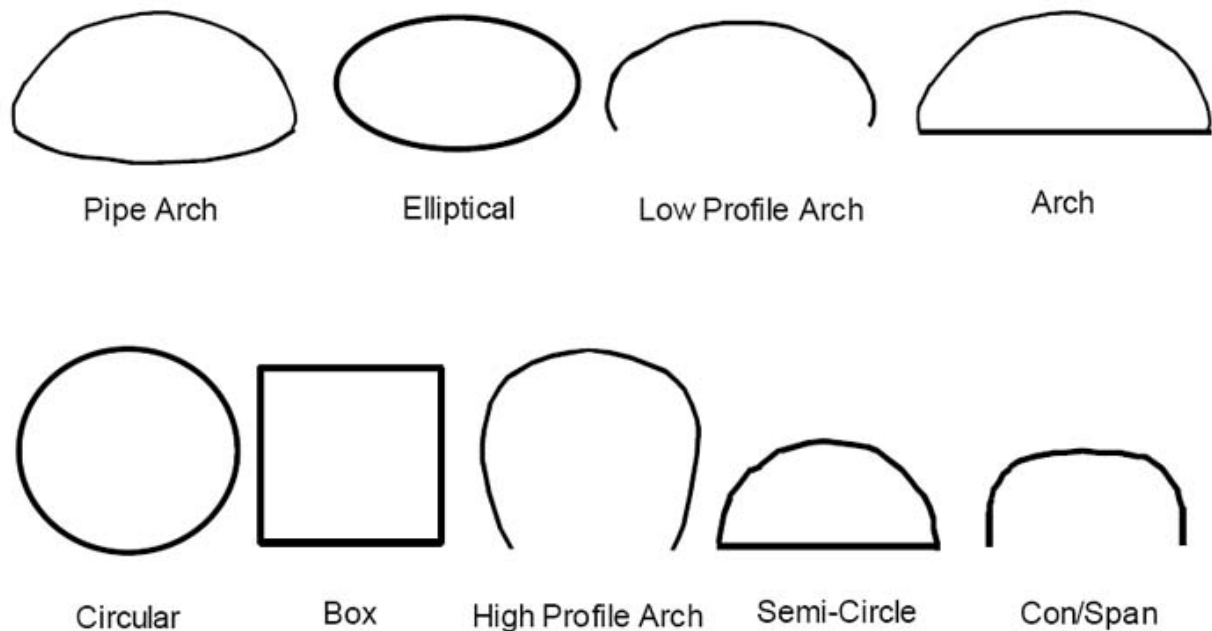

Figure 6.2 Commonly used culvert shapes.

- The program has the ability to model up to ten different culvert types (any change in shape, slope, roughness, or chart and scale number requires the user to enter a new culvert type) at any given culvert crossing.
- For a given culvert type, the number of identical barrels is limited to 25.

Cross Section Locations

- The culvert routines in HEC-RAS require the same cross sections as the bridge routines.
- Four cross sections are required for a complete culvert model.
- This total includes one cross section sufficiently downstream from the culvert such that flow is not affected by the culvert, one at the downstream end of the culvert, one at the upstream end of the culvert, and one cross section located far enough upstream that the culvert again has no effect on the flow.
- Note, the cross sections at the two ends of the culvert represent the channel outside of the culvert.
- Separate culvert data will be used to create cross sections inside of the culvert.
- Figure 6.3 illustrates the cross sections required for a culvert model.
- The cross sections are labeled 1, 2, 3, and 4 for the purpose of discussion within this chapter.

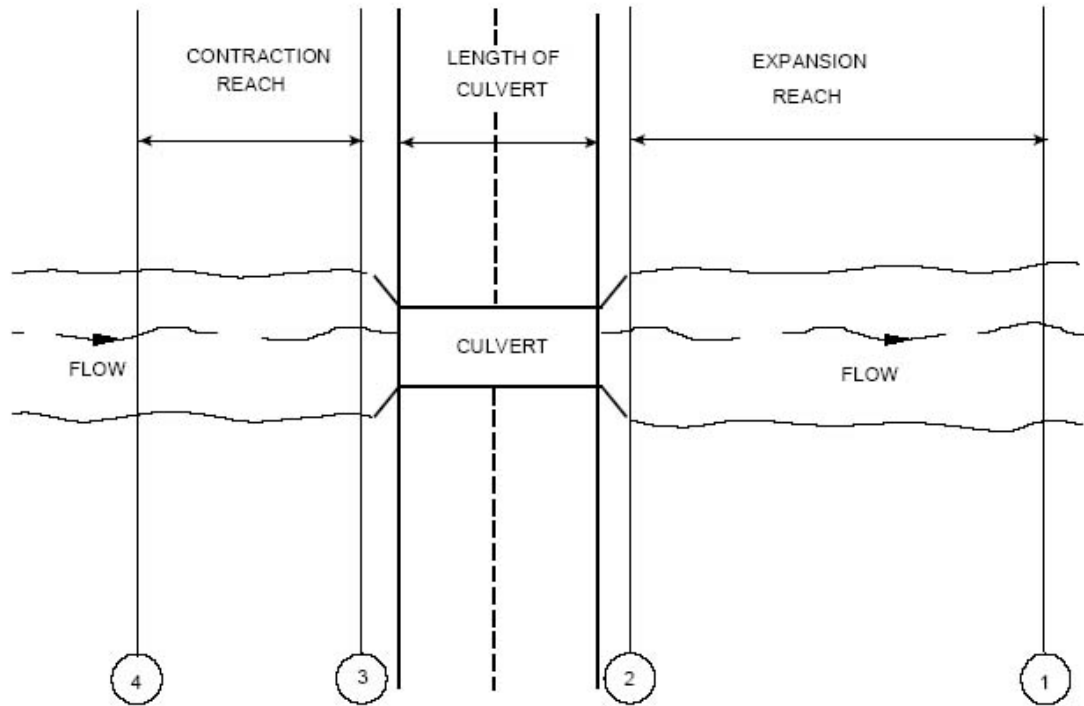

Figure 6.3 Cross section layout for culvert method.

- Whenever the user is computing a water surface profile through a culvert (or any other hydraulic structure), additional cross sections should always be included both upstream and downstream of the structure.
- This will prevent any user-entered boundary conditions from affecting the hydraulic results through the culvert.

Cross Section 1 of Culvert Model

- Cross Section 1 for a culvert model should be located at a point where flow has fully expanded from its constricted top width caused by the culvert constriction.
- The cross section spacing downstream of the culvert can be based on the criterion stated under the bridge modeling chapter (See Chapter 5, Modeling Bridges for a more complete discussion of cross section locations).
- The entire area of Cross Section 1 is usually considered to be effective in conveying flow.

Cross Section 2 of Culvert Model

- Cross Section 2 of a culvert model is located a short distance downstream from the culvert exit.
- It does not include any of the culvert structure or embankments, but represents the physical shape of the channel just downstream of the culvert.
- The shape and location of this cross section is entered separately from the Bridge and Culvert editor in the user interface (cross section editor).

- The HEC-RAS ineffective area option is used to restrict the effective flow area of Cross Section 2 to the flow area around or near the edges of the culverts, until flow overtops the roadway.
- The ineffective flow areas are used to represent the correct amount of active flow area just downstream of the culvert.
- Because the flow will begin to expand as it exits the culvert, the active flow area at Section 2 is generally wider than the width of the culvert opening.
- The width of the active flow area will depend upon how far downstream Cross Section 2 is from the culvert exit.
- In general, a reasonable assumption would be to assume a 1.5:1 expansion rate over this short distance.
- With this assumption, if Cross Section 2 were 6 feet from the culvert exit, then the active flow area at Section 2 should be 8 feet wider than the culvert opening (4 feet on each side of the culvert).
- Figure 6.4 illustrates Cross Section 2 of a typical culvert model with a box culvert.

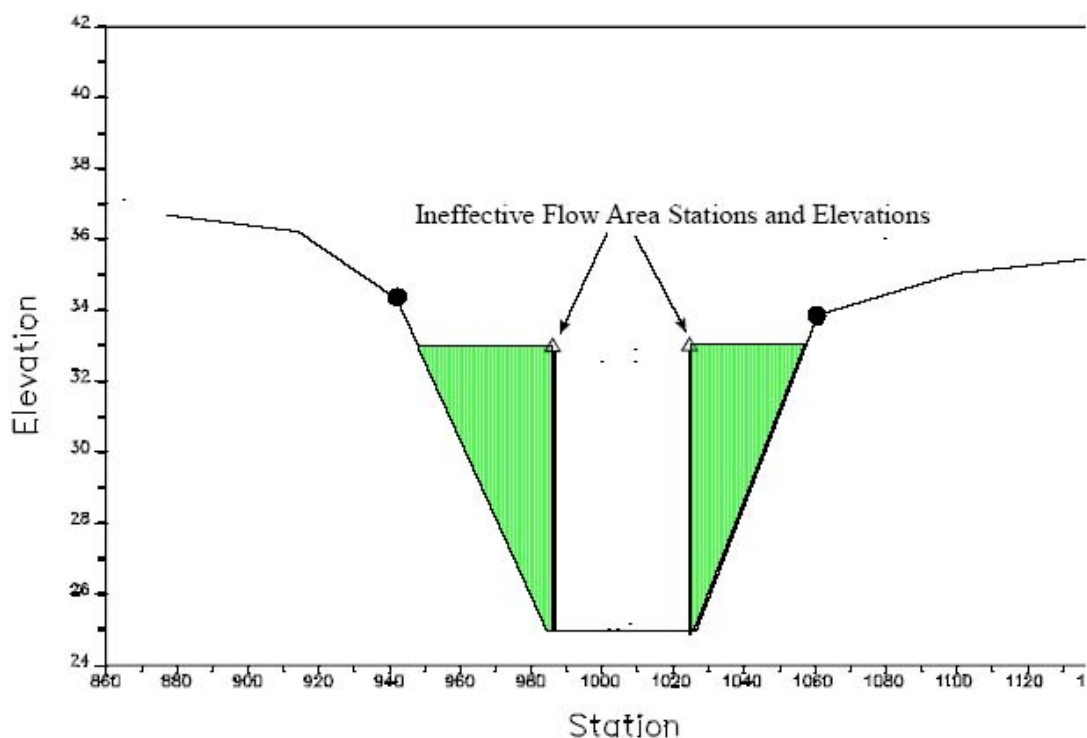

Figure 6.4 Cross section 2 of culvert model.

- As indicated, the cross section data does not define the culvert shape for the culvert model.
- On Figure 6.4, the channel bank locations are indicated by small circles, and the stations and elevations of the ineffective flow areas are indicated by triangles.

- **Cross Sections 1 and 2 are located so as to create a channel reach downstream of the culvert in which the HEC-RAS program can accurately compute the friction losses and expansion losses downstream of the culvert.**

Cross Section 3 of Culvert Model

- **Cross Section 3 of a culvert model is located a short distance upstream of the culvert entrance, and represents the physical configuration of the upstream channel.**
- **The culvert method uses a combination of a bridge deck, Cross Sections 2 and 3, and culvert data, to describe the culvert or culverts and the roadway embankment.**
- **The culvert data, which is used to describe the roadway embankment and culvert openings, is located at a river station between Cross Sections 2 and 3.**
- **The HEC-RAS ineffective area option is used to restrict the effective flow area of Cross Section 3 until the flow overtops the roadway.**
- **The ineffective flow area is used to represent the correct amount of active flow area just upstream of the culvert.**
- **Because the flow is contracting rapidly as it enters the culvert, the active flow area at Section 3 is generally wider than the width of the culvert opening.**
- **The width of the active flow area will depend upon how far upstream Cross Section 3 is placed from the culvert entrance.**
- **In general, a reasonable assumption would be to assume a 1:1 contraction rate over this short distance.**
- **With this assumption, if Cross Section 3 were 5 feet from the culvert entrance, then the active flow area at Section 3 should be 10 feet wider than the culvert opening (5 feet on each side of the culvert).**
- **Figure 6.5 illustrates Cross Section 3 of a typical culvert model for a box culvert, including the roadway profile defined by the bridge deck/roadway editor, and the culvert shape defined in the culvert editor.**

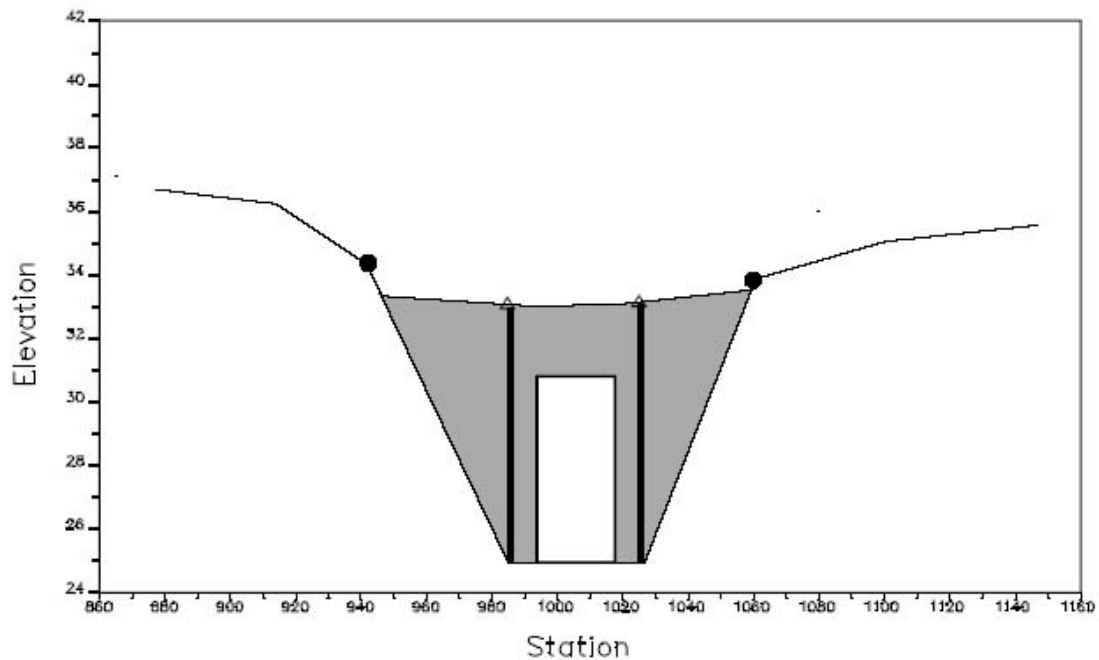

Figure 6.5 Cross section 3 of culvert model.

- As indicated, the ground profile does not define the culvert shape for the culvert model.
- On Figure 6.5, the channel bank locations are indicated by small circles and the stations and elevations of ineffective area control are indicated by triangles.

Cross Section 4 of Culvert Model

- The final cross section in the culvert model is located at a point where flow has not yet begun to contract from its unrestrained top width upstream of the culvert to its constricted top width near the culvert.
- This distance is normally determined assuming a one to one contraction of flow.
- In other words, the average rate at which flow can contract to pass through the culvert opening is assumed to be one foot laterally for every one foot traveled in the downstream direction.
- More detailed information on the placement of cross sections can be found in Chapter 5, Modeling Bridges.
- The entire area of Cross Section 4 is usually considered to be effective in conveying flow.

Expansion and Contraction Coefficients

- User-defined coefficients are required to compute head losses due to the contraction and expansion of flows upstream and downstream of a culvert.
- These losses are computed by multiplying an expansion or contraction coefficient by the absolute difference in velocity head between two cross sections.

- If the velocity head increases in the downstream direction, a contraction coefficient is applied.
- When the velocity head decreases in the downstream direction, an expansion coefficient is used.
- Recommended values for the expansion and contraction coefficients have been given in Chapter 3 of this manual (Table 3.2).
- As indicated by the tabulated values, the expansion of flow causes more energy loss than the contraction.
- Also, energy losses increase with the abruptness of the transition.
- For culverts with abrupt flow transitions, the contraction and expansion loss coefficients should be increased to account for additional energy losses.

Limitations of the Culvert Routines in HEC-RAS

- The HEC-RAS routines are limited to culverts that are considered to be constant in shape, flow rate, and bottom slope.

CULVERT HYDRAULICS

- This section introduces the basic concepts of culvert hydraulics, which are used in the HEC-RAS culvert routines.

Introduction to Culvert Terminology

- A culvert is a relatively short length of closed conduit, which connects two open channel segments or bodies of water.
- Two of the most common types of culverts are: circular pipe culverts, which are circular in cross section, and box culverts, which are rectangular in cross section.
- Figure 6.6 shows an illustration of circular pipe and box culverts.

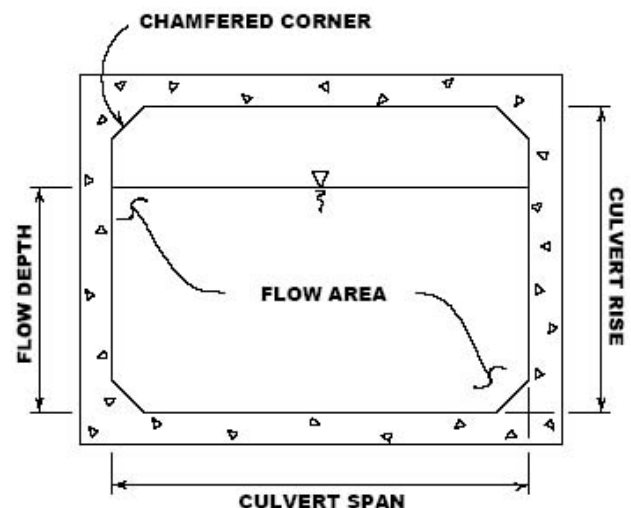
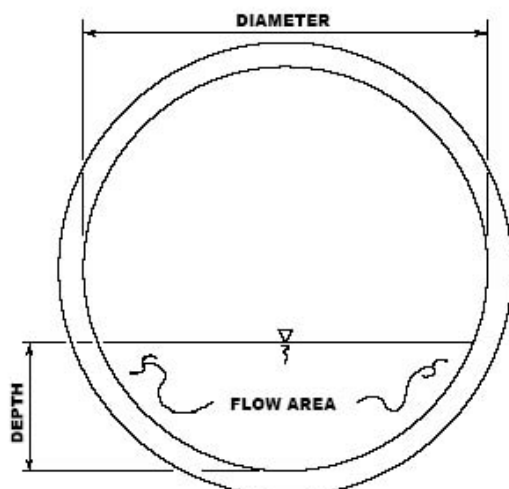

Figure 6.6 Cross section of a circular pipe and box culvert, respectively.

- In addition to box and pipe culverts, HEC-RAS has the ability to model arch; pipe arch; low profile arch; high profile arch; elliptical; semi-circular; and ConSpan culvert shapes.
- Culverts are made up of an entrance where water flows into the culvert, a barrel, which is the closed conduit portion of the culvert, and an exit, where the water flows out of the culvert (see Figure 6.7).

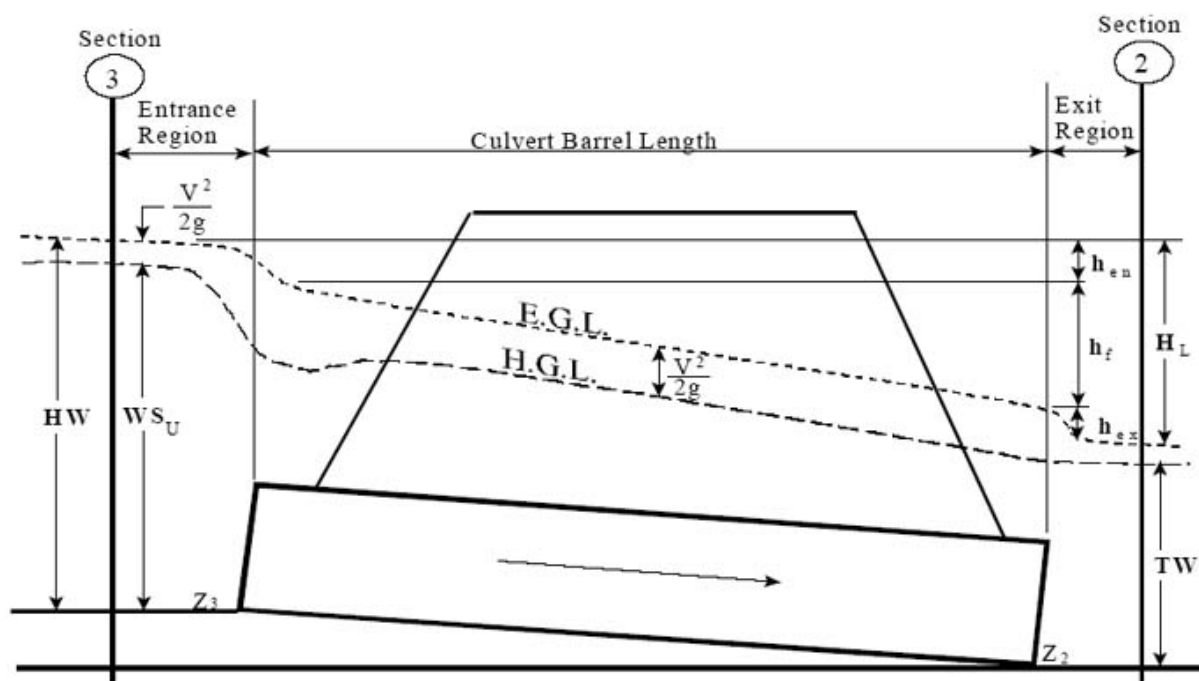

Figure 6.7 Full flowing culvert with energy and hydraulic gradelines.

- The total flow capacity of a culvert depends upon the characteristics of the entrance as well as the culvert barrel and exit.
- The Tailwater at a culvert is the depth of water on the exit or downstream side of the culvert, as measured from the downstream invert of the culvert (shown as TW on Figure 6.7).
- The invert is the lowest point on the inside of the culvert at a particular cross section.
- The tailwater depth depends on the flow rate and hydraulic conditions downstream of the culvert.
- Headwater (HW on Figure 6.7) is the depth from the culvert inlet invert to the energy grade line, for the cross section just upstream of the culvert (Section 3).
- The Headwater represents the amount of energy head required to pass a given flow through the culvert.

- **The Upstream Water Surface (WS_U on Figure 6.7) is the depth of water on the entrance or upstream side of the culvert (Section 3), as measured from the upstream invert of Cross Section 3.**
- **The Total Energy at any location is equal to the elevation of the invert plus the specific energy (depth of water + velocity head) at that location.**
- **All of the culvert computations within HEC-RAS compute the total energy for the upstream end of the culvert.**
- **The upstream water surface (WS_U) is then obtained by placing that energy into the upstream cross section and computing the water surface that corresponds to that energy for the given flow rate.**

Flow Analysis for Culverts

- **The analysis of flow in culverts is quite complicated.**
- **It is common to use the concepts of inlet control and outlet control to simplify the analysis.**
- **Inlet control flow occurs when the flow capacity of the culvert entrance is less than the flow capacity of the culvert barrel.**
- **The control section of a culvert operating under inlet control is located just inside the entrance of the culvert.**
- **The water surface passes through critical depth at or near this location, and the flow regime immediately downstream is supercritical.**
- **For inlet control, the required upstream energy is computed by assuming that the culvert inlet acts as a sluice gate or as a weir.**
- **Therefore, the inlet control capacity depends primarily on the geometry of the culvert entrance.**
- **Outlet control flow occurs when the culvert flow capacity is limited by downstream conditions (high tailwater) or by the flow carrying capacity of the culvert barrel.**
- **The HEC-RAS culvert routines compute the upstream energy required to produce a given flow rate through the culvert for inlet control conditions and for outlet control conditions (Figure 6.8).**

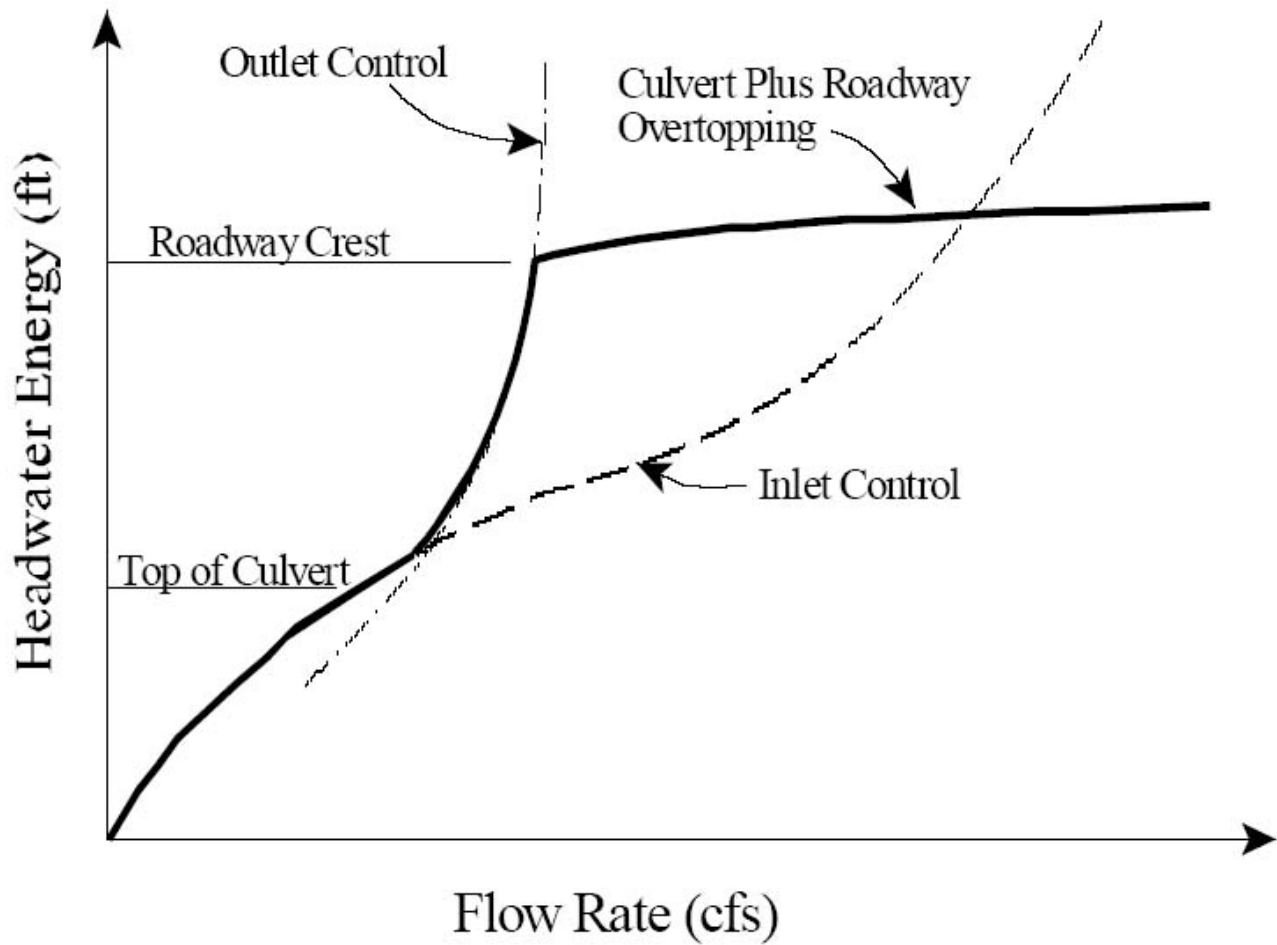

Figure 6.8 Culvert performance curve with roadway overtopping.

- In general, the higher upstream energy "controls" and determines the type of flow in the culvert for a given flow rate and tailwater condition.
- For outlet control, the required upstream energy is computed by performing an energy balance from the downstream section to the upstream section.
- The HEC-RAS culvert routines consider entrance losses, friction losses in the culvert barrel, and exit losses at the outlet in computing the outlet control headwater of the culvert.
- During the computations, if the inlet control answer comes out higher than the outlet control answer, the program will perform some additional computations to evaluate if the inlet control answer can actually persist through the culvert without pressurizing the culvert barrel.
- The assumption of inlet control is that the flow passes through critical depth near the culvert inlet and transitions into supercritical flow.
- If the flow persists as low flow through the length of the culvert barrel, then inlet control is assumed to be valid.
- If the flow goes through a hydraulic jump inside the barrel, and fully develops the entire area of the culvert, it is assumed that this condition will cause the pipe to pressurize over

the entire length of the culvert barrel and thus act more like an orifice type of flow.

- If this occurs, then the outlet control answer (under the assumption of a full flowing barrel) is used instead of the inlet control answer.

Computing Inlet Control Headwater

- For inlet control conditions, the capacity of the culvert is limited by the capacity of the culvert opening, rather than by conditions farther downstream.
- Extensive laboratory tests by the National Bureau of Standards, the Bureau of Public Roads, and other entities resulted in a series of equations, which describe the inlet control headwater under various conditions.
- These equations form the basis of the FHWA inlet control nomographs shown in the Hydraulic Design of Highway Culverts publication [FHWA, 1985].
- The FHWA inlet control equations are used by the HEC-RAS culvert routines in computing the upstream energy.
- The inlet control equations were developed for submerged and unsubmerged inlet conditions.
- These equations are:

Unsubmerged Inlet:

$$HW_i / D = H_c / D + K [Q / (AD^{1/2})]^M - 0.5 S \quad (6-1)$$

$$HW_i / D = K [Q / (AD^{1/2})]^M \quad (6-2)$$

Submerged Inlet:

$$HW_i / D = c [Q / (AD^{1/2})]^M + Y - 0.5 S \quad (6-3)$$

where

- HW_i = Headwater energy depth above the invert of the culvert inlet, feet
- D = interior height of the culvert barrel, feet
- H_c = specific head at critical depth, feet
- Q = discharge through the culvert, cfs
- A = full cross-sectional area of the culvert barrel, square feet
- S = culvert barrel slope, feet/feet
- K , M , c , and Y = equation constants, which vary depending on culvert shape and entrance conditions

- Note that there are two forms of the unsubmerged inlet equation.

- The first form (equation 6-1) is more correct from a theoretical standpoint, but form two (equation 6-2) is easier to apply and is the only documented form of equation for some of the culvert types.
- Both forms of the equations are used in the HEC-RAS software, depending on the type of culvert.
- The nomographs in the FHWA report are considered to be accurate to within about 10 percent in determining the required inlet control headwater [FHWA, 1985].
- The nomographs were computed assuming a culvert slope of 0.02 feet per foot (2 percent).
- For different culvert slopes, the nomographs are less accurate because inlet control headwater changes with slope.
- However, the culvert routines in HEC-RAS consider the slope in computing the inlet control energy.
- Therefore, the culvert routines in HEC-RAS should be more accurate than the nomographs, especially for slopes other than 0.02 feet per foot.

Computing Outlet Control Headwater

- For outlet control flow, the required upstream energy to pass the given flow must be computed considering several conditions within the culvert and downstream of the culvert.
- Figure 6.9 illustrates the logic of the outlet control computations.

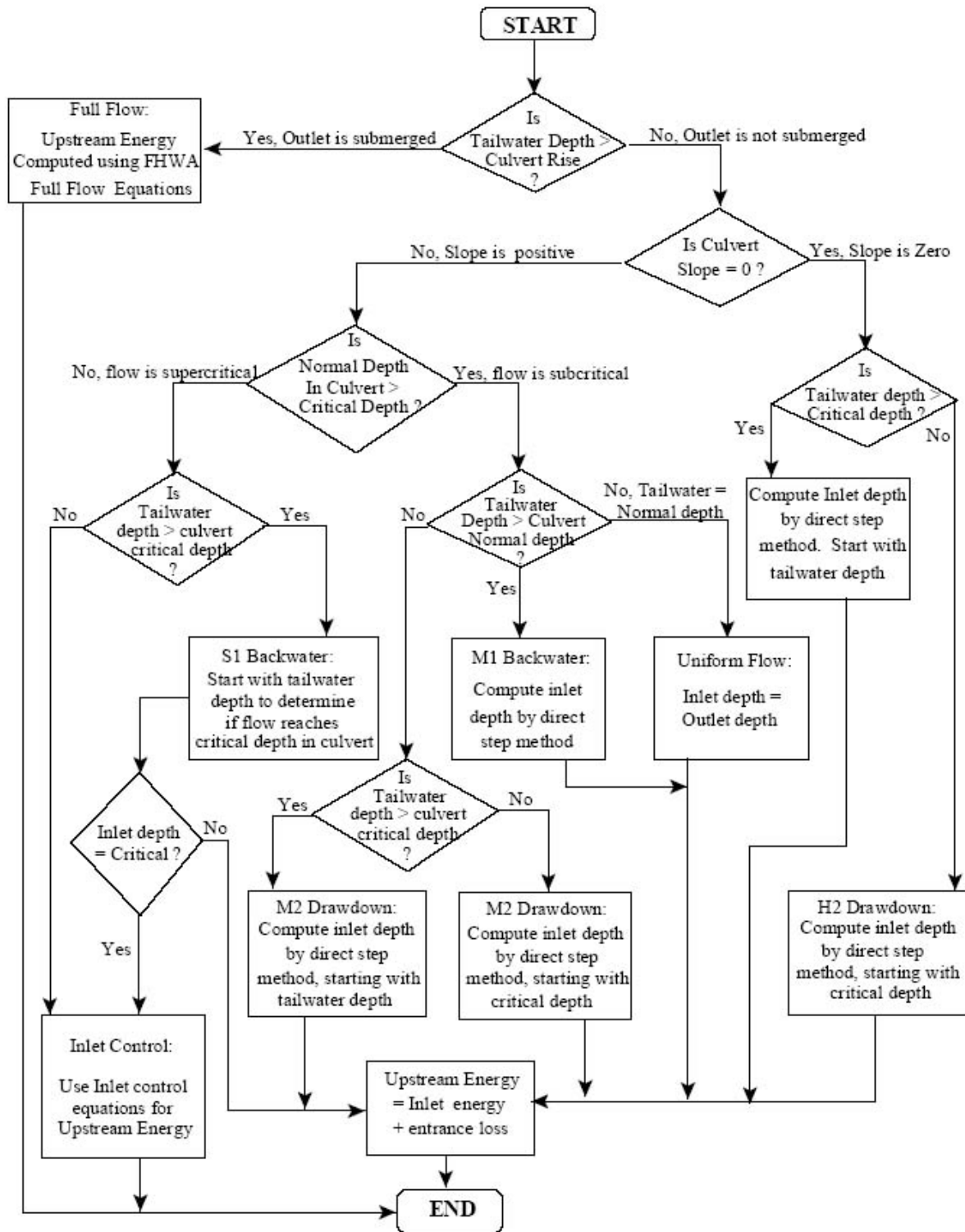

Figure 6.9 Flow chart for outlet control computations.

- HEC-RAS uses Bernoulli's equation in order to compute the change in energy through the culvert under outlet control conditions.
- The outlet control computations are energy based.
- The equation used by the program is the following:

$$Z_3 + Y_3 + \alpha_3 V_3^2 / (2g) = Z_2 + Y_2 + \alpha_2 V_2^2 / (2g) + H_L \quad (6-4)$$

where

- Z_3 = upstream invert elevation of the culvert
- Y_3 = depth of water above the upstream culvert inlet
- V_3 = the average velocity upstream of the culvert
- α_3 = the velocity weighting coefficient upstream of the culvert
- g = acceleration of gravity
-
- Z_2 = downstream invert elevation of the culvert
- Y_2 = depth of water above the downstream culvert inlet
- V_2 = the average velocity downstream of the culvert
- α_2 = the velocity weighting coefficient downstream of the culvert
- H_L = total energy loss through the culvert (from section 2 to 3).

FHWA Full Flow Equations

- For culverts flowing full, the total head loss, or energy loss, through the culvert is measured in feet (or meters).
- The head loss, H_L , is computed using the following formula:

$$H_L = h_{en} + h_f + h_{ex} \quad (6-5)$$

where

- h_{en} = entrance loss
- h_f = friction loss
- h_{ex} = exit loss
- The friction loss in the culvert is computed using Manning's formula, which is expressed as follows:

$$h_f = L [(Qn) / (1.486 A R^{2/3})]^2 \quad (6-6)$$

where

- h_f = friction loss
- L = culvert length
- Q = flow rate in the culvert

- n = Manning's n roughness coefficient
- A = flow area
- R = hydraulics radius
- The entrance energy loss is computed as a coefficient times the velocity head inside the culvert at the upstream end.
- The exit energy loss is computed as a coefficient times the change in velocity head from just inside the culvert, at the downstream end, to outside of the culvert at the downstream end.
- The exit and entrance loss coefficients are described in the next section of this chapter.

Direct Step Water Surface Profile Computations

- For culverts flowing partially full, the water surface profile in the culvert is computed using the direct step method.
- This method is very efficient, because no iterations are required to determine the flow depth for each step.
- The water surface profile is computed for small increments of depth (usually between 0.01 and 0.05 feet).
- If the flow depth equals the height of the culvert before the profile reaches the upstream end of the culvert, the friction loss through the remainder of the culvert is computed assuming full flow.
- The first step in the direct step method is to compute the exit loss and establish a starting water surface inside the culvert.
- If the tailwater depth is below critical depth inside the culvert, then the starting condition inside the culvert is assumed to be critical depth.
- If the tailwater depth is greater than critical depth in the culvert, then an energy balance is performed from the downstream cross section to inside of the culvert.
- This energy balance evaluates the change in energy by the following equation.

$$Z_C + Y_C + \alpha_C V_C^2 / (2g) = Z_2 + Y_2 + \alpha_2 V_2^2 / (2g) + h_{ex} \quad (6-7)$$

where

- Z_C = elevation of the culvert inlet at the downstream end
- Y_C = depth of flow inside culvert at downstream end
- V_C = velocity inside culvert at downstream end
- α_C = the velocity weighting coefficient inside culvert at downstream end
- g = acceleration of gravity

- Z_2 = invert elevation of the cross section downstream of the culvert (cross section 2 from Figure 6.7)
- Y_2 = depth of water at cross section 2
- V_2 = average velocity at cross section 2
- α_2 = the velocity weighting coefficient at cross section 2
- h_{ex} = exit loss.

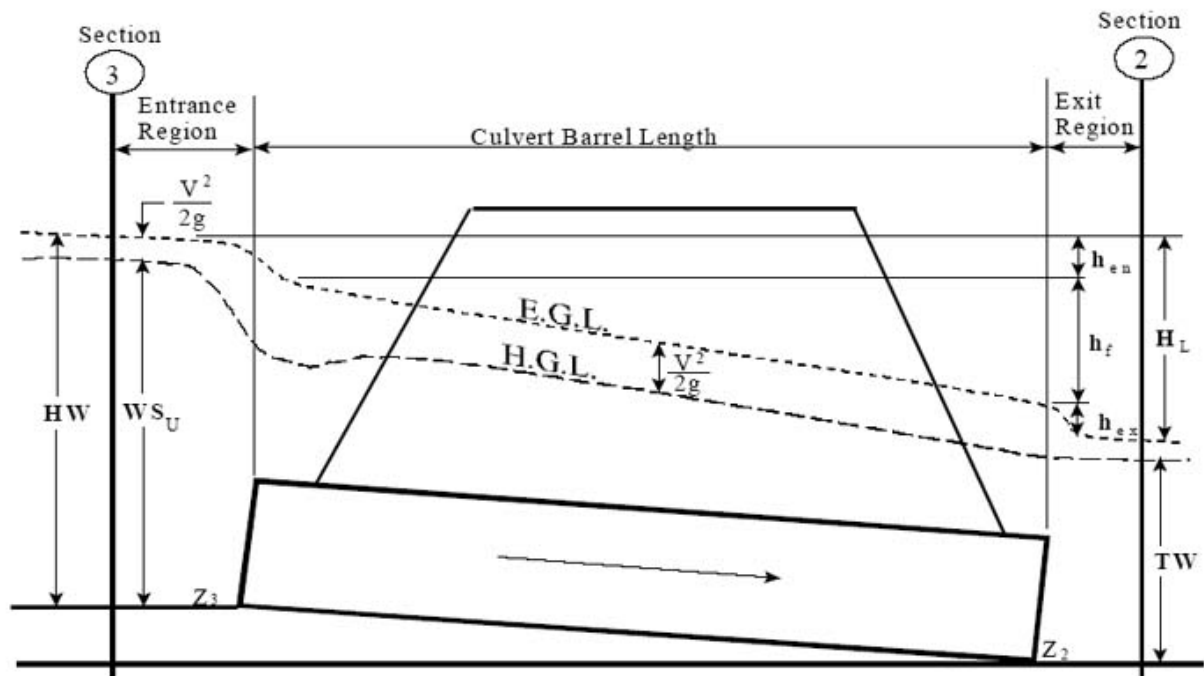

Figure 6.7 Full flowing culvert with energy and hydraulic gradelines.

- Once a water surface is computed inside the culvert at the downstream end, the next step is to perform the direct step backwater calculations through the culvert.
- The direct step backwater calculations will continue until a water surface and energy are obtained inside the culvert at the upstream end.
- The final step is to add an entrance loss to the computed energy to obtain the upstream energy outside of the culvert at Section 3 (Figure 6.7).
- The water surface outside the culvert is then obtained by computing the water surface at Section 3 that corresponds to the calculated energy for the given flow rate.

Normal Depth of Flow in the Culvert

- Normal depth is the depth at which uniform flow will occur in an open channel.
- In other words, for a uniform channel of infinite length, carrying a constant flow rate, flow in the channel would be at a constant depth at all points along the channel, and this would be the normal depth.

- Normal depth often represents a good approximation of the actual depth of flow within a channel segment.
- The program computes normal depth using an iterative approach to arrive at a value, which satisfies Manning's equation:

$$Q = (1.486/n) A R^{2/3} S_f^{1/2} \quad (6-8)$$

where

- Q = flow rate in the channel
 - n = Manning's n roughness coefficient
 - A = flow area
 - R = hydraulics radius
 - S_f = slope of energy grade line
- If the normal depth is greater than the culvert rise (from invert to top of the culvert), the program sets the normal depth equal to the culvert rise.

Critical Depth of Flow in the Culvert

- Critical depth occurs when the flow in a channel has a minimum specific energy.
- Specific energy refers to the sum of the depth of flow and the velocity head.
- Critical depth depends on the channel shape and flow rate.
- The depth of flow at the culvert outlet is assumed to be equal to critical depth for culverts operating under outlet control with low tailwater.
- Critical depth may also influence the inlet control headwater for unsubmerged conditions.
- The culvert routines compute critical depth in the culvert by an iterative procedure, which arrives at a value satisfying the following equation:

$$Q^2/g = A^3/T \quad (6-9)$$

where

- Q = flow rate in the channel
 - g = gravitational acceleration
 - A = cross sectional flow area
 - T = top width of flow
- Critical depth for box culverts can be solved directly with the following equation [AISI, 1980]:

$$y_c = [q^2/g]^{1/3} \quad (6-10)$$

where

- y_c = critical depth
- q = unit-width discharge
- g = gravitational acceleration

Horizontal and Adverse Culvert Slopes

- The culvert routines also allow for horizontal and adverse culvert slopes.
- The primary difference is that normal depth is not computed for a horizontal or adverse culvert.
- Outlet control is either computed by the direct step method for an unsubmerged outlet or the full flow equation for a submerged outlet.

Weir Flow

- The first solution through the culvert is under the assumption that all of the flow is going through the culvert barrels.
- Once a final upstream energy is obtained, the program checks to see if the energy elevation is greater than the minimum elevation for weir flow to occur.
- If the computed energy is less than the minimum elevation for weir flow, then the solution is final.
- If the computed energy is greater than the minimum elevation for weir flow, the program performs an iterative procedure to determine the amount of flow over the weir and through the culverts.
- During this iterative procedure, the program recalculates both inlet and outlet control culvert solutions for each estimate of the culvert flow.
- In general the higher of the two is used for the culvert portion of the solution, unless the program feels that inlet control cannot be maintained.
- The program will continue to iterate until it finds a flow split that produces the same upstream energy (within the error tolerance) for both weir and culvert flow.

Supercritical and Mixed Flow Regime Inside of Culvert

- The culvert routines allow for supercritical and mixed flow regimes inside the culvert barrel.
- During outlet control computations, the program first makes a subcritical flow pass through the culvert, from downstream to upstream.
- If the culvert barrel is on a steep slope, the program may default to critical depth inside of the culvert barrel.
- If this occurs, a supercritical forewater calculation is made from upstream to downstream, starting with the assumption of critical depth at the culvert inlet.

- During the forewater calculations, the program is continually checking the specific force of the flow, and comparing it to the specific force of the flow from the subcritical flow pass.
- If the specific force of the subcritical flow is larger than the supercritical answer, the program assumes that a hydraulic jump will occur at that location.
- Otherwise, a supercritical flow profile is calculated all the way through and out of the culvert barrel.

Multiple Manning's n Values Inside of Culvert

- This version of HEC-RAS allows the user to enter two Manning's n values inside of the culvert, one for the top and sides, and a second for the culvert bottom.
- The user defines the depth inside the culvert to which the bottom n value is applied.
- This feature can be used to simulate culverts that have a natural stream bottom, or a culvert that has the bottom portion rougher than the top, or if something has been placed in the bottom of the culvert for fish passage.
- An example of this is shown in Figure 6.10.

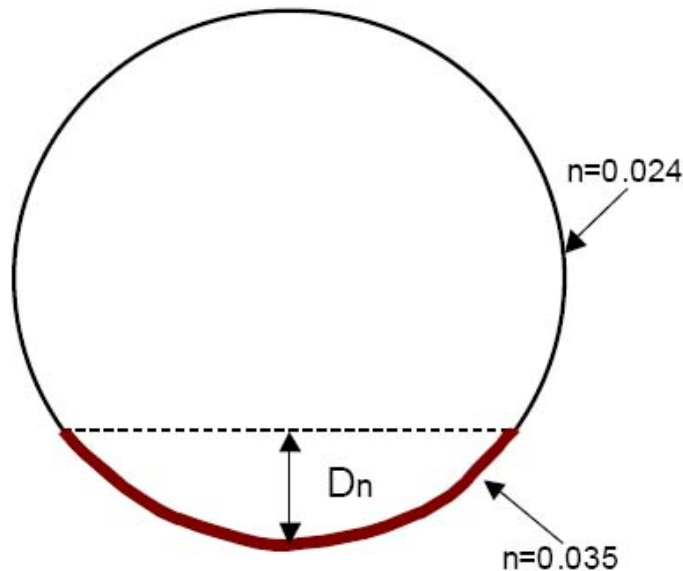

Figure 6.10 Culvert with multiple Manning's n values.

- When multiple Manning's n values are applied to a culvert, the computational program will use the bottom n value until the water surface goes above the specified bottom n value.
- When the water surface goes above the bottom n value depth the program calculates a composite n value for the culvert as a whole.
- This composite n value is based on an equation from Chow's book on Open Channel Hydraulics (Chow, 1959) and is the same equation we use for computing a composite n value in open channel flow (see equation 2- 6, from chapter 2 of this manual).

Partially Filled or Buried Culverts

- This version of HEC-RAS allows the user to fill in a portion of the culvert from the bottom.
- This option can be applied to any of the culvert shapes.
- The user is only required to specify the depth to which the culvert bottom is filled in.
- An example of this is shown in figure 6.11.

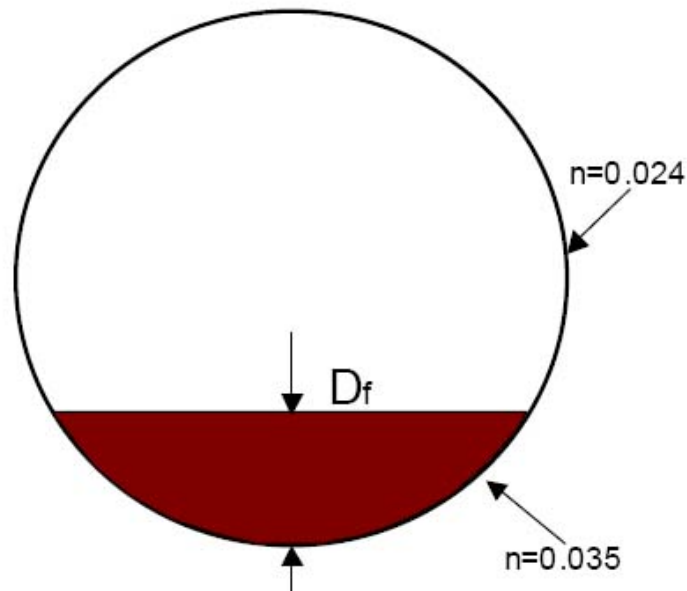

Figure 6.11 Partially Filled or Buried Culverts.

- The user can also specify a different Manning's n value for the blocked portion of the culvert (the bottom), versus the remainder of the culvert.
- The user must specify the depth to apply the bottom n value as being equal to the depth of the filled portion of the culvert.

CULVERT DATA AND COEFFICIENTS

- This section describes the basic data that are required for each culvert.
- Discussions include how to estimate the various coefficients that are required in order to perform inlet control, outlet control, and weir flow analyses.
- The culvert data are entered on the Culvert Data Editor in the user interface.
- Discussions about the culvert data editor can be found in Chapter 6 of the HEC-RAS User's Manual.

Culvert Shape and Size

- The shape of the culvert is defined by picking one of the nine available shapes.
- These shapes include: circular; box (rectangular); arch; pipe arch; elliptical; high profile arch; low profile arch; semi-circular; and ConSpan.
- The size of the culvert is defined by entering a rise and span.
- The rise refers to the maximum inside height of the culvert, while the span represents the maximum inside width.
- Both the circular and semi-circular culverts are defined by entering a diameter.
- The inside height (rise) of a culvert opening is important not only in determining the total flow area of the culvert, but also in determining whether the headwater and tailwater elevations are adequate to submerge the inlet or outlet of the culvert.
- Most box culverts have chamfered corners on the inside, as indicated in Figure 6.6.

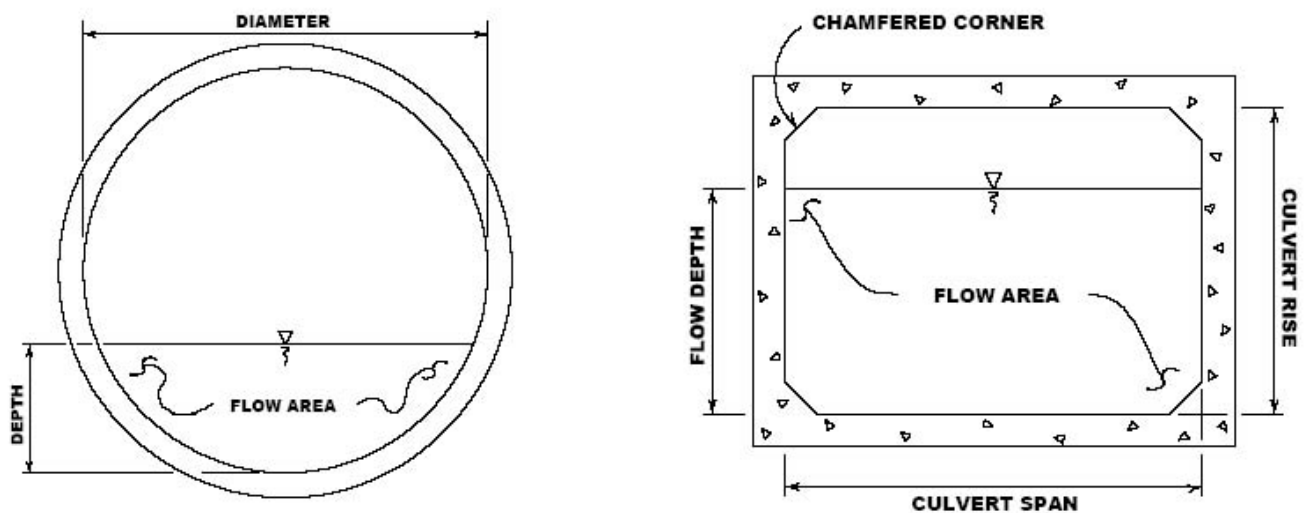

Figure 6.6 Cross section of a circular pipe and box culvert, respectively.

- The chamfers are ignored by the culvert routines in computing the cross-sectional area of the culvert opening.
- Some manufacturers' literature contains the true cross-sectional area for each size of box culvert, considering the reduction in area caused by the chamfered corners.
- If you wish to consider the loss in area due to the chamfers, then you should reduce the span of the culvert.
- You should not reduce the rise of the culvert, because the program uses the culvert rise to determine the submergence of the culvert entrance and outlet.

- All of the arch culverts (arch, pipe arch, low profile arch, high profile arch, and ConSpan arch) within HEC-RAS have pre-defined sizes.
- However, the user can specify any size they want.
- When a size is entered that is not one of the pre-defined sizes, the program interpolates the hydraulic properties of the culvert from tables (except for ConSpan culverts).
- HEC-RAS has 9 predefined Conspan arches.
- Conspan arches are composed of two vertical walls and an arch.
- Each predefined span has a predefined arch height, for example the 12 ft arch has an arch height of 3.07 ft.
- For the 12 span, any rise greater than 3.07 ft can be made by adding vertical wall below the arch, when a rise is entered less than the arch height, the arch must be modified as discussed below.
- RAS has the ability to produce a culvert shape for rise and span combinations not in the predefined list.
- The following is a list of the pre-defined ConSpan sizes.

Predefined Spans	Arch Heights
12	3.00
14	3.00
16	3.53
20	4.13
24	4.93
28	5.76
32	6.51
36	7.39
42	9.19

- If a span is requested that is not in the list of predefined shapes, then one is interpolated geometrically from the bounding predefined shapes. The plot below (Figure 6.12) shows an interpolated 21 ft arch from 20 and 24 predefined arches.

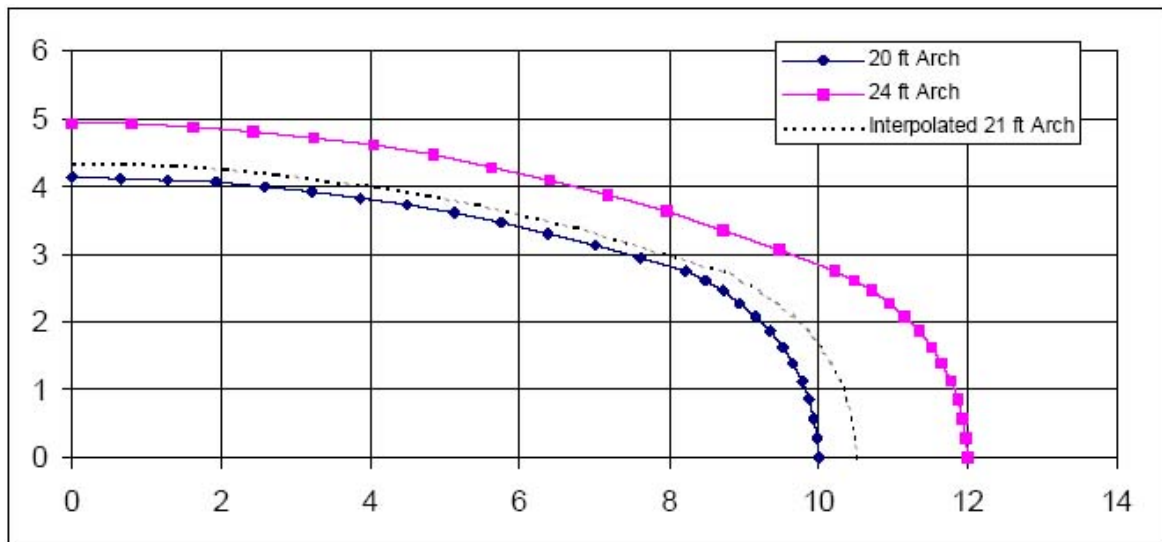

Figure 6.12 Geometric Interpolation of ConSpan Culvert for Non- Standard Widths (Span)

- If the span is less that the smallest predefined arch, then the smallest arch is scaled to the requested span, similarly, if a span is entered larger than the largest predefined arch, then the largest arch is scaled to the requested span.
- If a rise is entered that is less that the predefined arch rise, then the vertical ordinates of the arch are scaled down to the requested arch rise and no vertical segments are added.
- In the plot below (Figure 6.13), a 20 ft span was requested with a 3 ft rise.

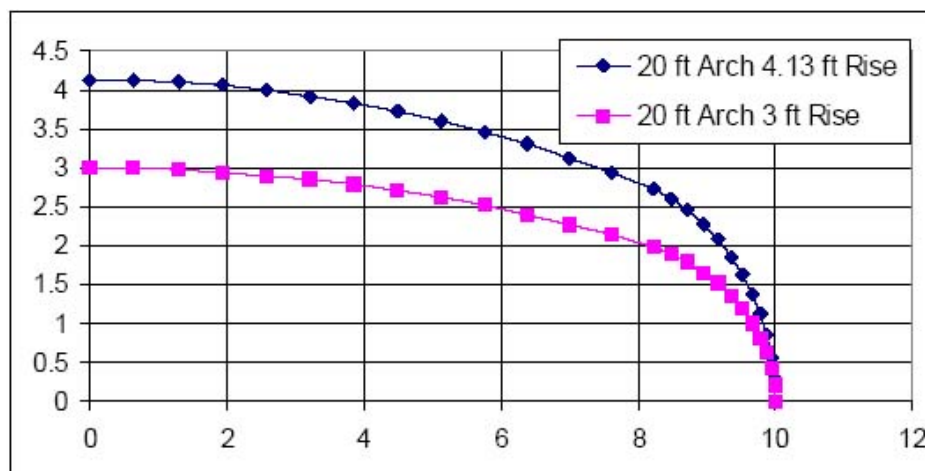

Figure 6.13 Geometric Interpolation of the ConSpan Culvert for Non-Standard Rise.

- The arch height of the 20 ft span is 4.13 feet so all the vertical distances were multiplied by $3 / 4.13$.

Culvert Length

- The culvert length is measured in feet (or meters) along the center-line of the culvert. The culvert length is used to determine the friction loss in the culvert barrel and the slope of the culvert.

Number of Identical Barrels

- The user can specify up to 25 identical barrels.
- To use the identical barrel option, all of the culverts must be identical; they must have the same cross-sectional shape and size, chart and scale number, length, entrance and exit loss coefficients, upstream and downstream invert elevations, and roughness coefficients.
- If more than one barrel is specified, the program automatically divides the flow rate equally among the culvert barrels and then analyzes only a single culvert barrel.
- The hydraulics of each barrel is assumed to be exactly the same as the one analyzed.

Manning's Roughness Coefficient

- The Manning's roughness coefficients must be entered for each culvert type.
- HEC-RAS uses Manning's equation to compute friction losses in the culvert barrel, as described in the section entitled "Culvert Hydraulics" of this chapter.
- Suggested values for Manning's n-value are listed in Table 6.1 and Table 6.2, and in many hydraulics reference books.

Table 6.1 Manning's n for closed conduits flowing partially full

Type of Channel and Description	Minimum	Normal	Maximum
Brass, smooth:	0.009	0.010	0.013
Steel:			
Lockbar and welded	0.010	0.012	0.014
Riveted and spiral	0.013	0.016	0.017
Cast Iron:			
Coated	0.010	0.013	0.014
Uncoated	0.011	0.014	0.016
Wrought Iron:			
Black	0.012	0.014	0.015
Galvanized	0.013	0.016	0.017
Corrugated Metal:			
Subdrain	0.017	0.019	0.021
Storm Drain	0.021	0.024	0.030
Lucite:	0.008	0.009	0.010
Glass:	0.009	0.010	0.013
Cement:			
Neat, surface	0.010	0.011	0.013
Mortar	0.011	0.013	0.015
Concrete:			
Culvert, straight and free of debris	0.010	0.011	0.013
Culvert with bends, connections, and some debris	0.011	0.013	0.014
Finished	0.011	0.012	0.014
Sewer with manholes, inlet, etc., straight	0.013	0.015	0.017
Unfinished, steel form	0.012	0.013	0.014
Unfinished, smooth wood form	0.012	0.014	0.016
Unfinished, rough wood form	0.015	0.017	0.020
Wood:			
Stave	0.010	0.012	0.014
Laminated, treated	0.015	0.017	0.020
Clay:			
Common drainage tile	0.011	0.013	0.017
Vitrified sewer	0.011	0.014	0.017
Vitrified sewer with manholes, inlet, etc.	0.013	0.015	0.017
Vitrified Subdrain with open joint	0.014	0.016	0.018
Brickwork:			
Glazed	0.011	0.013	0.015
Lined with cement mortar	0.012	0.015	0.017
Sanitary sewers coated with sewage slime with bends and connections	0.012	0.013	0.016
Paved invert, sewer, smooth bottom	0.016	0.019	0.020
Rubble masonry, cemented	0.018	0.025	0.030

Table 6.2 Manning's n for corrugated metal pipe

Type of Pipe and Diameter	Unpaved	25% Paved	Fully Paved
Annular 2.67 x 2 in. (all diameters) Helical 1.50 x 1/4 in.:	0.024	0.021	0.021
8 inch diameter	0.012		
10 inch diameter	0.014		
Helical 2.67 x 2 inc.:			
12 inch diameter	0.011		
18 inch diameter	0.014		
24 inch diameter	0.016	0.015	0.012
36 inch diameter	0.019	0.017	0.012
48 inch diameter	0.020	0.020	0.012
60 inch diameter	0.021	0.019	0.012
Annular 3 x 1 in. (all diameters)	0.027	0.023	0.012
Helical 3 x 1 in.:			
48 inch diameter	0.023	0.020	0.012
54 inch diameter	0.023	0.020	0.012
60 inch diameter	0.024	0.021	0.012
66 inch diameter	0.025	0.022	0.012
72 inch diameter	0.026	0.022	0.012
78 inch & larger	0.027	0.023	0.012
Corrugations 6 x 2 in.:			
60 inch diameter	0.033	0.028	
72 inch diameter	0.032	0.027	
120 inch diameter	0.030	0.026	
180 inch diameter	0.028	0.024	

- Roughness coefficients should be adjusted according to individual judgment of the culvert condition.

Entrance Loss Coefficient

- Entrance losses are computed as a function of the velocity head inside the culvert at the upstream end.
- The entrance loss for the culvert is computed as:

$$h_{en} = k_{en} V_{en}^2 / (2g) \quad (6-11)$$

where

Table 6.3 indicates that values of the entrance loss coefficient range from 0.2 to about 0.9 for pipe-arch and pipe

- h_{en} = energy loss due to entrance
- k_{en} = entrance loss coefficient
- V_{en} = flow velocity inside the culvert at the entrance
- g = gravitational acceleration
- The velocity head is multiplied by the entrance loss coefficient to estimate the amount of energy lost as flow enters the culvert.
- A higher value for the coefficient gives a higher head loss.

- Entrance loss coefficients are shown in Tables 6.3, 6.4, and 6.5.
- These coefficients were taken from the Federal Highway Administration's "Hydraulic Design of Highway Culverts" manual (FHWA, 1985).
- Table 6.3 indicates that values of the entrance loss coefficient range from 0.2 to about 0.9 for pipe-arch and pipe culverts.

Table 6.3 Entrance loss coefficient for pipe culverts

Type of Structure and Design of Entrance	Coefficient, k_{en}
Concrete Pipe Projecting from Fill (no headwall):	
Socket end of pipe	0.2
Square cut end of pipe	0.5
Concrete Pipe with Headwall or Headwall and Wingwalls:	
Socket end of pipe (grooved end)	0.2
Square cut end of pipe	0.5
Rounded entrance, with rounding radius = 1/12 of diameter	0.2
Concrete Pipe:	
Mitered to conform to fill slope	0.7
End section conformed to fill slope	0.5
Beveled edges, 33.7 or 45 degree bevels	0.2
Side slope tapered inlet	0.2
Corrugated Metal Pipe or Pipe-Arch:	
Projected from fill (no headwall)	0.9
Headwall or headwall and wingwalls square edge	0.5
Mitered to conform to fill slope	0.7
End section conformed to fill slope	0.5
Beveled edges, 33.7 or 45 degree bevels	0.2
Side slope tapered inlet	0.2

- As shown in Table 6.4, entrance losses can vary from about 0.2 to about 0.7 times the velocity head for box culverts.

Table 6.4 Entrance loss coefficient for reinforced concrete box culverts

Type of Structure and Design of Entrance	Coefficient, k_{en}
Headwall Parallel to Embankment (no wingwalls):	
Square-edged on three edges	0.5
Three edges rounded to radius of 1/12 barrel dimension	0.2
Wingwalls at 30 to 75 degrees to Barrel:	
Square-edge at crown	0.4
Top corner rounded to radius of 1/12 barrel dimension	0.2
Wingwalls at 10 to 25 degrees to Barrel:	
Square-edge at crown	0.5
Wingwalls parallel (extension of sides):	
Square-edge at crown	0.7
Side or slope tapered inlet	0.2

- For a sharp-edged culvert entrance with no rounding, 0.5 is recommended.
- For a well-rounded entrance, 0.2 is appropriate.
- Table 6.5 list entrance loss coefficients for ConSpan culverts.

Table 6.5 Entrance loss coefficients for ConSpan culverts	
Type of entrance	Coefficient k_{en}
Extended wingwalls 0 degrees	0.5
45 degree wingwalls	0.3
Straight headwall	0.4

Exit Loss Coefficient

- Exit losses are computed as a coefficient times the change in velocity head from just inside the culvert, at the downstream end, to the cross section just downstream of the culvert.
- The equation for computing exit losses is as follows:

$$h_{ex} = k_{ex} \{ [\alpha_{ex} V_{ex}^2 / (2g)] - [\alpha_2 V_2^2 / (2g)] \} \quad (6-12)$$

where

- h_{ex} = energy loss due to exit
 - k_{ex} = exit loss coefficient
 - V_{ex} = flow velocity inside the culvert at exit
 - α_{ex} = the velocity weighting coefficient at exit cross section
 - V_2 = flow velocity outside the culvert at downstream cross section
 - α_2 = the velocity weighting coefficient at downstream cross section
 - g = gravitational acceleration
- For a sudden expansion of flow, such as in a typical culvert, the exit loss coefficient (k_{ex}) is normally set to 1.0 (FHWA, 1985).
 - In general, exit loss coefficients can vary between 0.3 and 1.0.
 - The exit loss coefficient should be reduced as the transition becomes less abrupt.

FHWA Chart and Scale Numbers

- **The FHWA chart and scale numbers are required input data.**
- **The FHWA chart number and scale number refer to a series of nomographs published by the Bureau of Public Roads (now called the Federal Highway Administration) in 1965 [BPR, 1965], which allowed the inlet control headwater to be computed for different types of culverts operating under a wide range of flow conditions.**
- **These nomographs and others constructed using the original methods were republished [FHWA, 1985].**
- **The tables in this chapter are copies of the information from the 1985 FHWA publication.**

- **Each of the FHWA charts has from two to four separate scales representing different culvert entrance designs.**
- **The appropriate FHWA chart number and scale number should be chosen according to the type of culvert and culvert entrance.**
- **Table 6.6 may be used for guidance in selecting the FHWA chart number and scale number.**

Table 6.1 (a) FHWA chart and scale numbers for culverts

Chart Number	Scale Number	Description
1		Concrete Pipe Culvert
	1	Square edge entrance with headwall (See Figure 6.10)
	2	Groove end entrance with headwall (See Figure 6.10)
	3	Groove end entrance, pipe projecting from fill (See Figure 6.12)
2		Corrugated Metal Pipe Culvert
	1	Headwall (See Figure 6.10)
	2	Mitered to conform to slope (See Figure 6.11)
	3	Pipe projecting from fill (See Figure 6.12)
3		Concrete Pipe Culvert; Beveled Ring Entrance (See Figure 6.13)
	1(A) 2(B)	Small bevel: $b/D = 0.042$; $a/D = 0.063$; $c/D = 0.042$; $d/D = 0.083$ Large bevel: $b/D = 0.083$; $a/D = 0.125$; $c/D = 0.042$; $d/D = 0.125$
8		Box Culvert with Flared Wingwalls (See Figure 6.14)
	1	Wingwalls flared 30 to 75 degrees
	2	Wingwalls flared 90 or 15 degrees
	3	Wingwalls flared 0 degrees (sides extended straight)
9		Box Culvert with Flared Wingwalls and Inlet Top Edge Bevel (See Figure 6.15)
	1 2	Wingwall flared 45 degrees; inlet top edge bevel = $0.43D$ Wingwall flared 18 to 33.7 degrees; inlet top edge bevel = $0.083D$
10		Box Culvert; 90-degree Headwall; Chamfered or Beveled Inlet Edges (See Figure 6.16)
	1	Inlet edges chamfered 3/4-inch
	2	Inlet edges beveled 2-in/ft at 45 degrees (1:1)
	3	Inlet edges beveled 1-in/ft at 33.7 degrees (1:1.5)
11		Box Culvert; Skewed Headwall; Chamfered or Beveled Inlet Edges (See Figure 6.17)
	1	Headwall skewed 45 degrees; inlet edges chamfered 3/4-inch
	2	Headwall skewed 30 degrees; inlet edges chamfered 3/4-inch
	3	Headwall skewed 15 degrees; inlet edges chamfered 3/4-inch
	4	Headwall skewed 10 to 45 degrees; inlet edges beveled
12		Box Culvert; Non-Offset Flared Wingwalls; 3/4-inch Chamfer at Top of Inlet (See Figure 6.18)
	1	Wingwalls flared 45 degrees (1:1); inlet not skewed
	2	Wingwalls flared 18.4 degrees (3:1); inlet not skewed
	3	Wingwalls flared 18.4 degrees (3:1); inlet skewed 30 degrees
13		Box Culvert; Offset Flared Wingwalls; Beveled Edge at Top of Inlet (See Figure 6.19)
	1	Wingwalls flared 45 degrees (1:1); inlet top edge bevel = $0.042D$
	2	Wingwalls flared 33.7 degrees (1.5:1); inlet top edge bevel = $0.083D$
	3	Wingwalls flared 18.4 degrees (3:1); inlet top edge bevel = $0.083D$
16-19		Corrugated Metal Box Culvert
	1	90 degree headwall
	2	Thick wall Projecting
	3	Thin wall projecting
29		Horizontal Ellipse; Concrete
	1	Square edge with headwall
	2	Grooved end with headwall
	3	Grooved end projecting
30		Vertical Ellipse; Concrete
	1	Square edge with headwall
	2	Grooved end with headwall
	3	Grooved end projecting
34		Pipe Arch; 18" Corner Radius; Corrugated Metal
	1	90 Degree headwall
	2	Mitered to slope
	3	Projecting

Table 6.6 (b) FHWA chart and scale numbers for culverts

Chart Number	Scale Number	Description
35		Pipe Arch; 18" Corner Radius; Corrugated Metal
	1	Projecting
	2	No bevels
	3	33.7 degree bevels
36		Pipe Arch; 31" Corner Radius; Corrugated Metal
	1	Projecting
	2	No bevels
	3	33.7 degree bevels
41-43		Arch; low-profile arch; high-profile arch; semi circle; Corrugated Metal
	1	90 degree headwall
	2	Mitered to slope
	3	Thin wall projecting
55		Circular Culvert
	1	Smooth tapered inlet throat
	2	Rough tapered inlet throat
56		Elliptical Inlet Face
	1	Tapered inlet; Beveled edges
	2	Tapered inlet; Square edges
	3	Tapered inlet; Thin edge projecting
57		Rectangular
	1	Tapered inlet throat
58		Rectangular Concrete
	1	Side tapered; Less favorable edges
	2	Side tapered; More favorable edges
59		Rectangular Concrete
	1	Slope tapered; Less favorable edges
	2	Slope tapered; More favorable edges
60		ConSpan Span/Rise Approximately 2:1
	1	0 degree wingwall angle
	2	45 degree wingwall angle
	3	90 degree wingwall angle
61		ConSpan Span/Rise Approximately 4:1
	1	0 degree wingwall angle
	2	45 degree wingwall angle
	3	90 degree wingwall angle

- Chart numbers 1, 2, and 3 apply only to pipe culverts.
- Similarly, chart numbers 8, 9, 10, 11, 12, and 13 apply only to box culverts.
- The HEC-RAS program checks the chart number to assure that it is appropriate for the type of culvert being analyzed.
- HEC-RAS also checks the value of the Scale Number to assure that it is available for the given chart number.
- For example, a scale number of 4 would be available for chart 11, but not for chart 12.
- Figures 6.14 through 6.23 can be used as guidance in determining which chart and scale numbers to select for various types of culvert inlets.

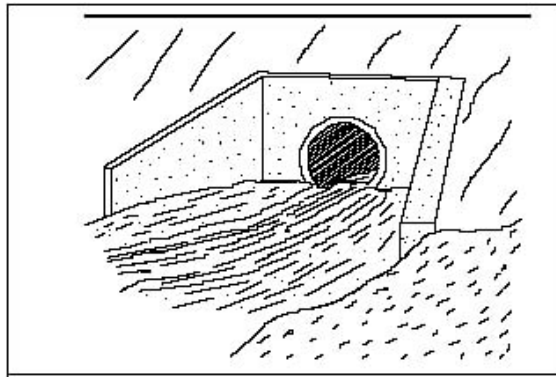

Figure 6.14 Culvert Inlet with Headwall and Wingwalls.

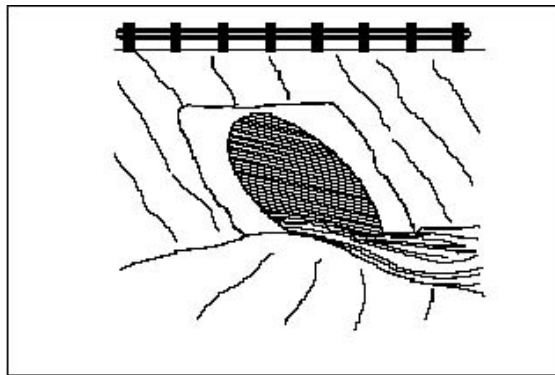

Figure 6.15 Culvert Inlet mitered to conform to slope.

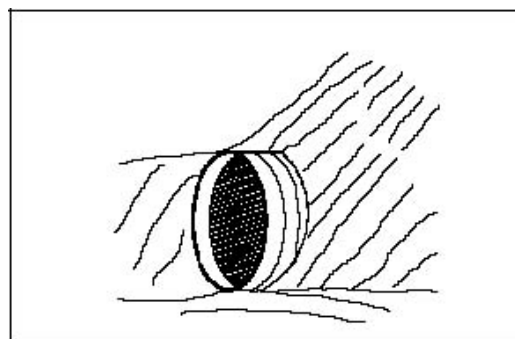

Figure 6.16 Culvert Inlet Projecting from Fill.

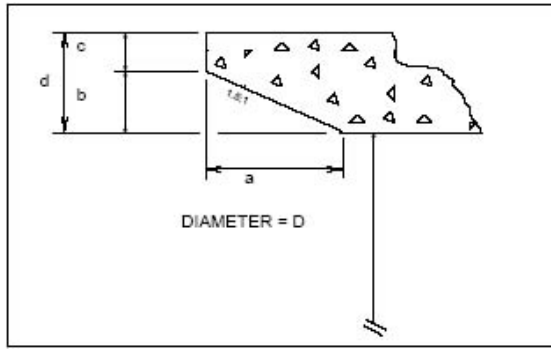

Figure 6.17 Culvert Inlet with Beveled Ring Entrance.

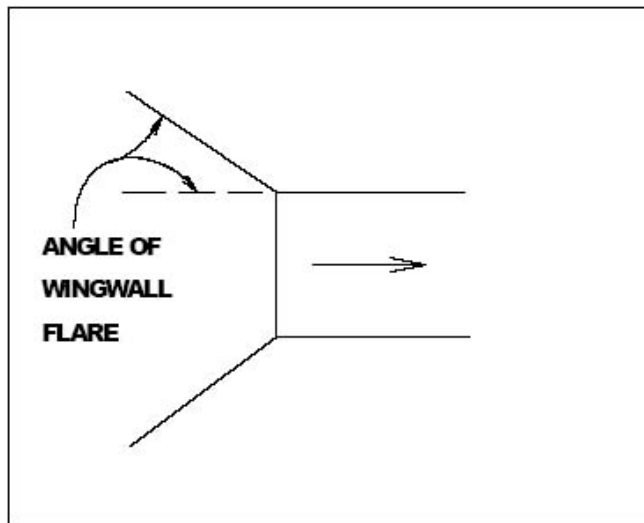

Figure 6.18 Flared Wingwalls (Chart 8).

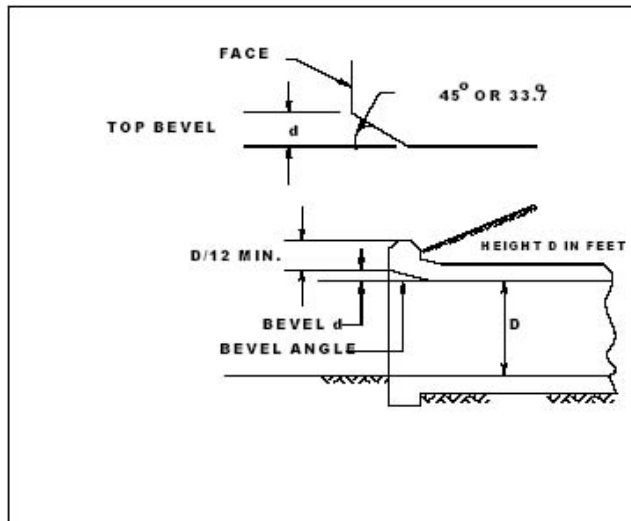

Figure 6.19 Inlet Top Edge Bevel (Chart 9).

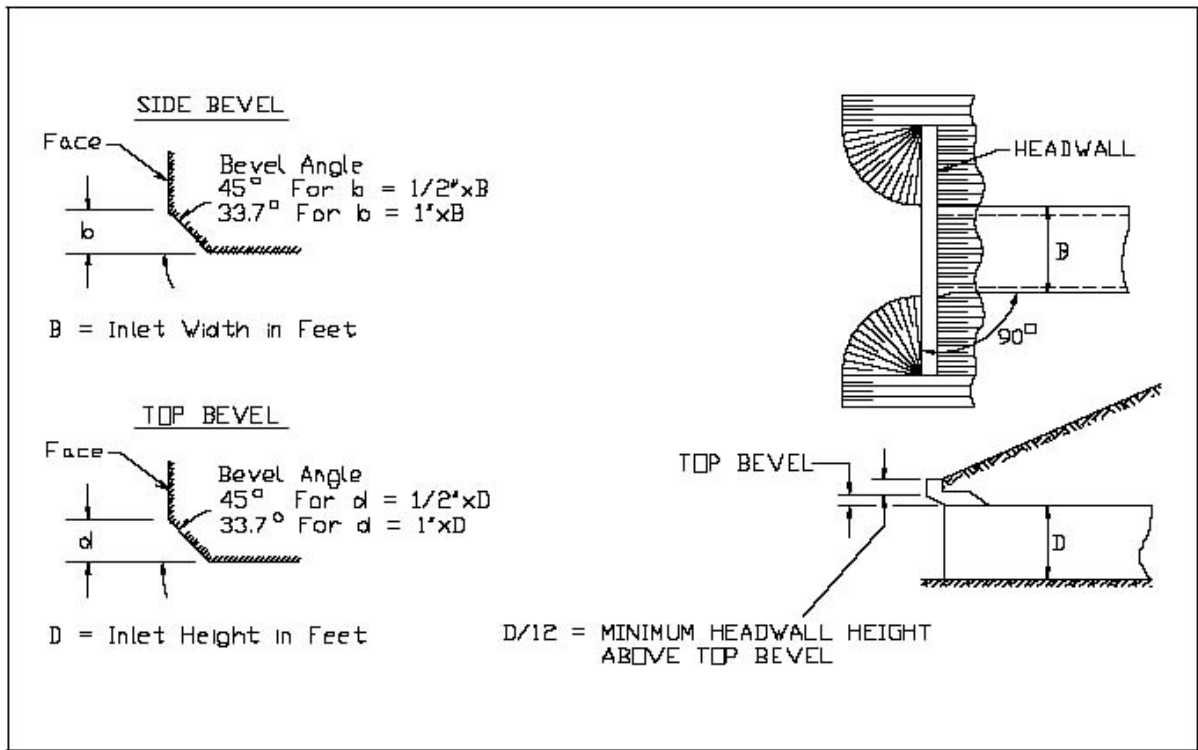

Figure 6.20 Inlet Side and Top Edge Bevel with Ninety Degree Headwall (Chart 10).

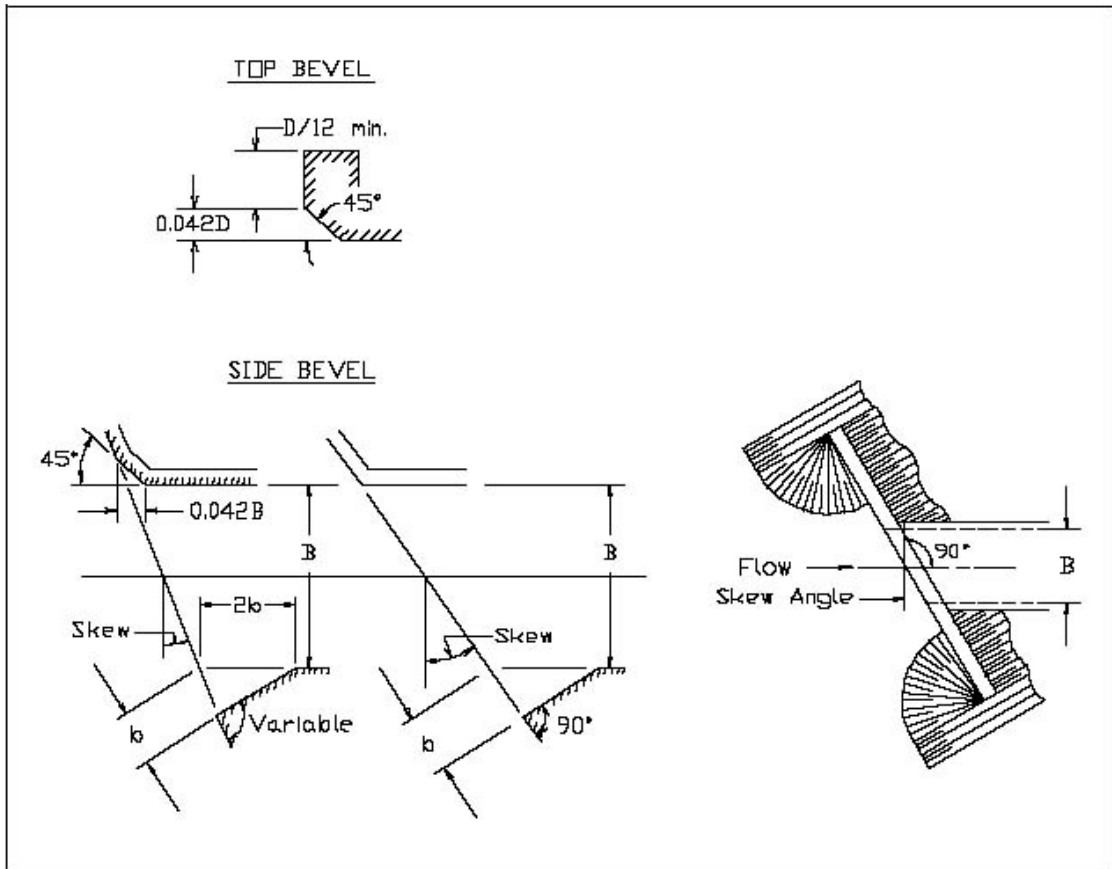

Figure 6.21 Inlet Side and Top Edge Bevel with Skewed Headwall (Chart 11).

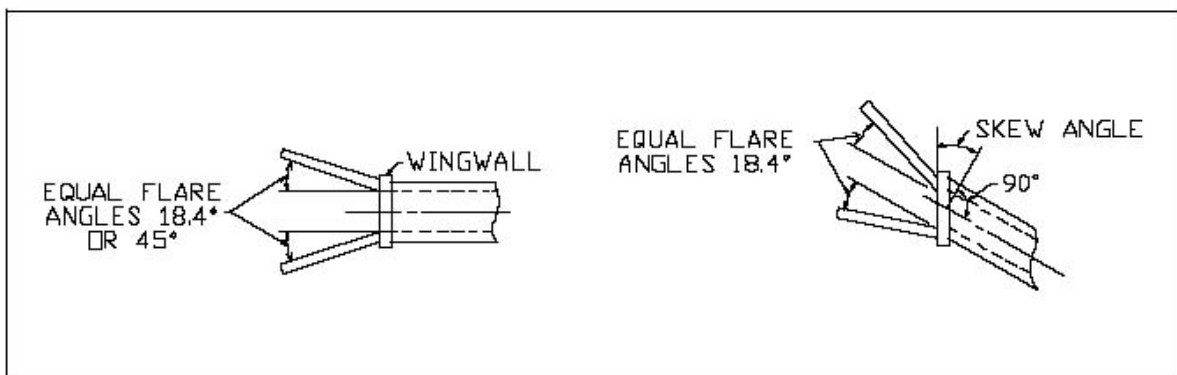

Figure 6.22 Non-Offset Flared Wingwalls (Chart 12).

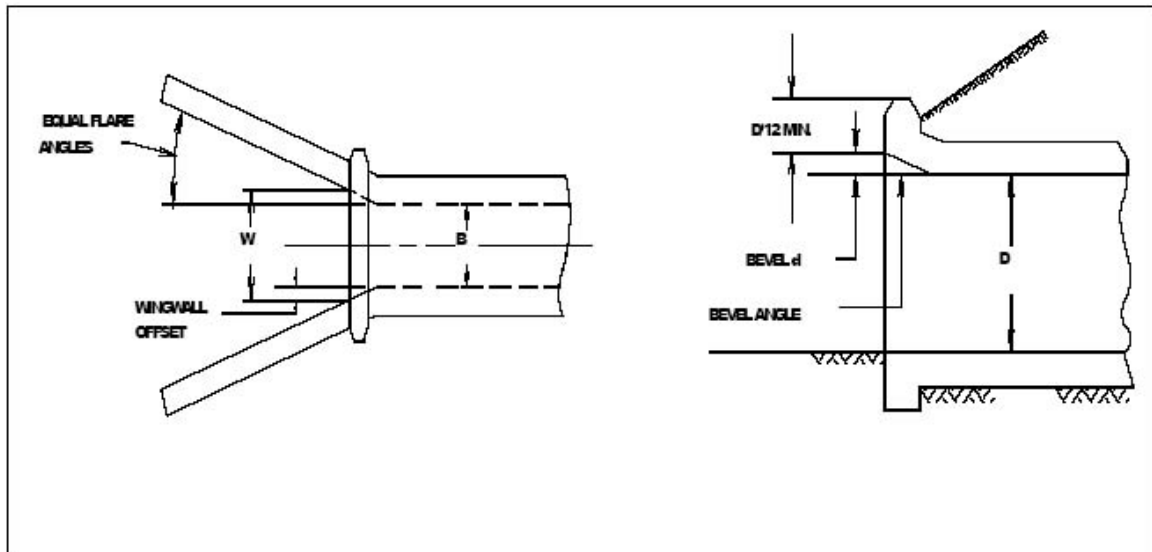

Figure 6.23 Offset Flared Wingwalls (Chart 13).

Culvert Invert Elevations

- The culvert flow-line slope is the average drop in elevation per foot of length along the culvert.
- For example, if the culvert flow-line drops 1 foot in a length of 100 feet, then the culvert flow-line slope is 0.01 feet per foot.
- Culvert flow-line slopes are sometimes expressed in percent.
- A slope of 0.01 feet per foot is the same as a one percent slope.
- The culvert slope is computed from the upstream invert elevation, the downstream invert elevation, and the culvert length.
- The following equation is used to compute the culvert slope:

$$S = (ELCHU - ELCHD) / [CULVLN^2 - (ELCHU - ELCHD)^2]^{1/2} \quad (6-13)$$

where

- ELCHU = elevation of the culvert inlet upstream
- ELCHD = elevation of the culvert inlet downstream
- CULVLN = length of the culvert
- The slope of the culvert is used by the program to compute the normal depth of flow in the culvert under outlet control conditions.

Weir Flow Coefficient

- Weir flow over a roadway is computed in the culvert routines using exactly the same methods used in the HEC-RAS bridge routines. The standard weir equation is used:

$$Q = C L H^{3/2} \quad (6-14)$$

where

- Q = flow rate;
 - C = weir flow coefficient;
 - L = weir length;and
 - H = weir energy head.
-
- For flow over a typical bridge deck, a weir coefficient of 2.6 is recommended.
 - A weir coefficient of 3.0 is recommended for flow over elevated roadway approach embankments.
 - More detailed information on weir discharge coefficients and how weirs are modeled in HEC-RAS may be found in Chapter 5 of this manual, "Modeling Bridges."
 - Also, information on how to enter a bridge deck and weir coefficients can be found in Chapter 6 of the HEC-RAS User's Manual, "Editing and Entering Geometric Data."

051108a